



VELOCITY CONTROL TECHNOLOGY

**VECTOR™
COMPRESSOR RECYCLE
ANTI-SURGE VALVES**

KOSO

The Koso VECTOR™ Compressor Recycle/ Anti-surge Solution

The optimum solution for safety and reliability, Koso's compressor recycle/anti-surge valve combines premium tortuous path VECTOR™ trim technology with fast-stroking reliable actuation. The result is a superior severe service valve solution designed to maximize the reliability, efficiency, and control of your compressor recycle system.

Anti-surge Applications Require Capacity and Control

The Koso VECTOR™ anti-surge valve design maximizes control while providing reliable and safe protection from compressor surge. The consequences of surge can be devastating - disrupting or tripping a process. Surge can damage equipment, and in catastrophic incidents, may cause the destruction of the compressor rotor. To avoid compressor surge, selection of the correct control valve is critical. Because the consequences of surge are too costly to ignore, surge protection from properly specified and engineered anti-surge/recycle valves is an important investment. The multiple stages of pressure letdown in the VECTOR™ trim control the fluid energy and eliminate vibration which is likely to occur in lesser valves.

VECTOR™ trim can be characterized to permit excellent low-flow control and high-flow capacity protection. The valve's capacity must be large enough to prevent surge under all operating conditions, including start-up and shut-down - without being oversized. Oversized valves provide poor control precision and will drive the compressor into choked flow when fully open.



Koso's fast-stroking pneumatic actuation provides precise resolution and control.



Dynamic testing of recirc valve for GE Thermodyn for Buzzard oil field in the North Sea.

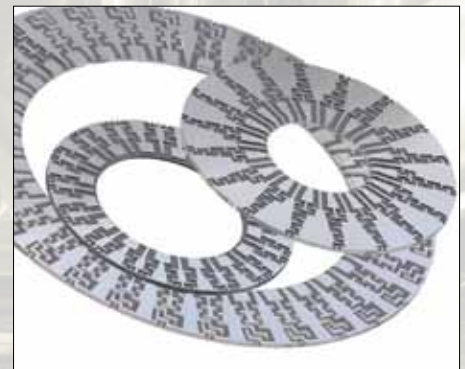

VECTOR™ multi-stage trim can be characterized to permit excellent low flow control and high-flow capacity protection.

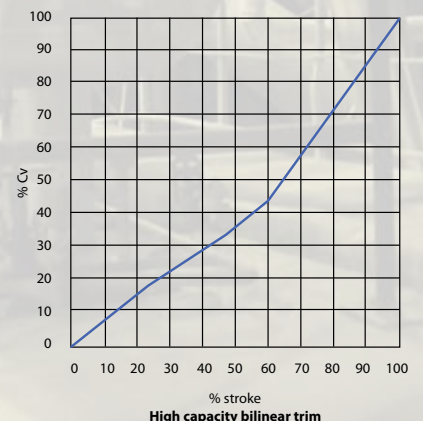
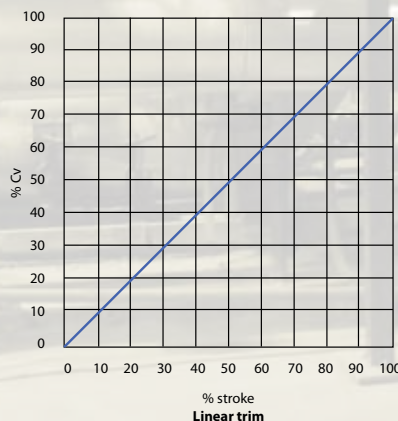

Performance characteristics.

* Front cover: One of three compressor recycle valves that replaced competitors valves on the North sea's largest FPSO vessel.

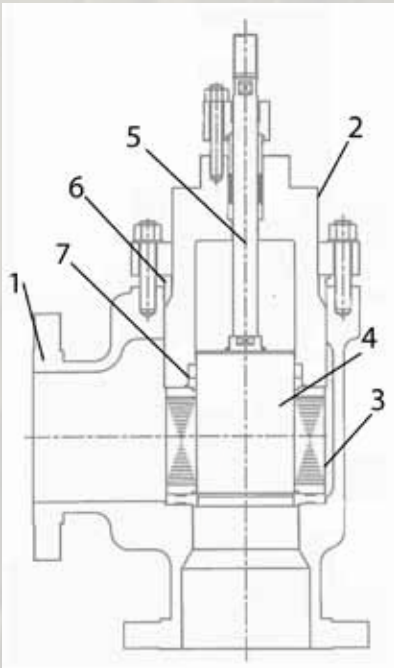

Table 1. Materials

Number	Component	Typical materials of construction
1	Body	A105, WCB, F316
2	Bonnet	A105, WCB, F316
3	Disk stack (cage)	316 SS
4	Plug	316 SS, 316 SS w/ Stellite
5	Stem	17-4 PH
6	Seat ring	316 SS, 316 SS w/ Stellite
7	Balance seal	Teflon

Table 2. Performance

Valve characteristics (% Cv vs. % opening)	Linear, bilinear
Shutoff class	ANSI/FCI Class VI or V
Actuator type	Double acting pneumatic piston
Modulating stroke speed	Open: <2 sec, close: <5 sec
Trip stroking speed	Less than 1 second
Fail mode	Open
Resolution	<1%



Four compressor recycle valves supplied to BP's Dimlington gas terminal.

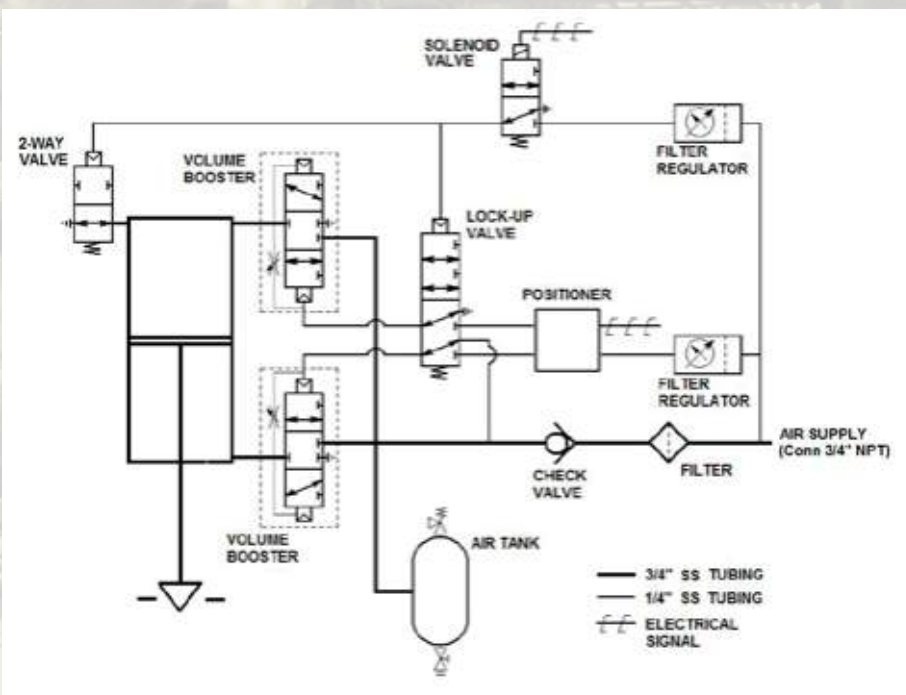

Typical anti-surge valve controls.

Reliability and control

When compressor bypass is needed in addition to anti-surge, slotted or drilled-hole-cage trim can be provided in the upper portion of the trim to provide additional capacity. VECTOR™ disks make up the lower portion of the trim, providing precise vibration-free control and maximum noise attenuation. The VECTOR™ trim design has evolved through decades of experience - solving severe service application challenges where durability, reliability and precise control are critical.

Koso's decades of experience developing advanced technology control valves and actuation systems has led to the development of the most reliable pneumatic actuation system available for a severe service control valve. Koso has supplied this design to customers worldwide for the past 20 plus years as a reliable, accurate, and fast-acting control solution. For anti-surge and recycle applications, Koso's pneumatic actuation system can deliver stroke speeds of less than one second while maintaining precise resolution and control.

Eliminate waste – optimize performance

During normal operation, any leakage past an anti-surge valve creates wasted energy and increased cost. A leaking anti-surge valve causes fluid to return to the suction side of the compressor, which causes the driver to work harder for the same output. Subsequently, the money spent compressing the additional gas is lost. VECTOR™ anti-surge valves are designed with either a soft or hard seat to ensure either an ANSI/FCI 70-2 Class VI or Class V shut-off - providing reliable and repeatable shut-off for long periods of time over very high pressure differentials. This results in substantial cost savings by eliminating lost energy from leakage and lost production.

Table 3. Typical services - valve applications in compressor recycle

Application	Differential pressure	Temperature	Inlet/Outlet
Gas production			
Separation	2.1-21 MPa (300-3000 psi)	37-93°C (100-200°F)	4-12"/6-16" 100-300mm/150-400mm
Reinjection	21 MPa (3000 psi)	37-65°C (100-150°F)	4-8"/6-8" 100-200mm/150-200mm
Gas			
Hydrogen	0.48-2.1 MPa (70-300 psi)	37-54°C (100-130°F)	6-12"/8-14" 150-300 mm/200-350mm
Natural gas	0.69-1 MPa (100-150 psi)	37-49°C (100-120°F)	8-24"/10-30" 150-300mm/250-750mm
Ammonia	0.34-0.69 MPa(50-100 psi)	37-93°C (100-200°F)	4-8"/6-12" 100-200mm/150-300mm
Air	0.34-4.8 MPa (50-700 psi)	37-93°C (100-200°F)	4-16"/6-24" 100-400mm/150-600mm
LNG			
Propane	0.55-2.7 MPa (80-400 psi)	-70-120°C (-94-248°F)	8-24"/10-24" 200-600mm/250-600mm
Material refrigerant	1-4.8 MPa (150-700 psi)	-45-100°C (-49-212°F)	12-24"/18-32" 300-600mm/450-800mm
FPSO			
LP	1.6 MPa (230 psi)	136°C (275°F)	6"/6" 150mm/150mm
MP	5.3 MPa (770 psi)	148°C (500°F)	6"/6" 150mm/150mm
HP	9.3 MPa (1350 psi)	45-50°C (113-122°F)	6"/6" 150mm/150mm
HHP	19.2 MPa (2780 psi)	45-50°C (113-122°F)	5 1/8"/5 1/8" 130mm/130mm



VECTOR™ anti-surge valve featuring 20 stages of pressure reduction for Surgutneftgas Station in Russia.



Headquarters

Nihon KOSO Co., LTD.
1-16-7, Nihombashi, Chuo-Ku
Tokyo, Japan, 103-0027
Tel: 81.3.5202.4100
Fax: 81.3.5202.1511
www.koso.co.jp/en/

Worldwide locations

- China
- France
- India
- Russia
- Singapore
- South Korea
- United Arab Emirates
- United Kingdom
- United States of America